

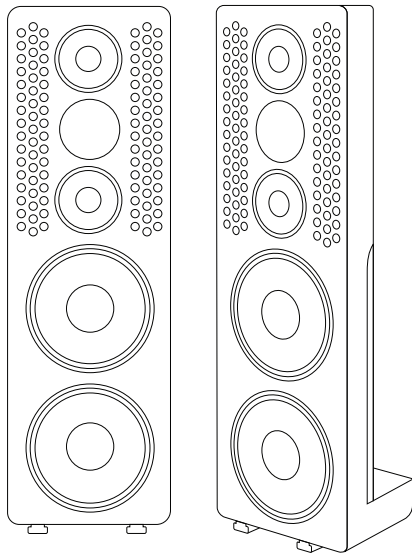

silent pound



1. General Information

Dear Customer,

Thank you for choosing Silent Pound speakers. To obtain the best possible listening experience, please read through and retain this manual for future reference.

Should you have inquiries, comments or suggestions regarding the speakers, please contact us at **support@silentpound.com**.

We also kindly suggest registering at **www.silentpound.com** to keep up to date with the latest news and promotions by Silent Pound.



1.1. Warranty and after sales support

We at *Silent Pound* craft our speakers to last and using only the best components. In an unlikely event of malfunction, we will repair or replace them free of charge.

Silent Pound limited warranty is valid for 2 years from purchase date and covers any failure or defect caused by faulty design, materials or craftsmanship.

Silent Pound limited warranty does not cover any damage:

- sustained during shipping;
- done by water or physical force;
- resulting from improper or incorrect use;
- obtained from failure to comply with safety instructions provided in this manual;
- resulting from any repairs or modifications done not by *Silent Pound* authorized personnel.

In an event covered by warranty please disconnect the speakers immediately and contact us at **support@silentpound.com** for further instructions. Please provide:

- proof of purchase, including date and place of purchase;
- description and (if possible) photos of defect.

We also kindly suggest to retain the original packaging so that the loudspeakers can be transported safely to an authorized service center.



2. Safety Information

Please read this owner's manual through carefully and retain it for future reference.

CAUTION! HEAVY LOAD! At least two adults should handle unpacking and positioning the speakers.

- When positioning the speakers, be sure to completely screw in the provided mounting legs and place the speakers on a solid perfectly level surface.
- Do not place heavy objects on loudspeakers to avoid compromising their stability.
- Do not expose the speakers to water or any other liquids. Do not expose the speakers to excessive moisture.

- Speakers emit electromagnetic field and can compromise functionality of certain electronic equipment, such as CRT monitors or TVs. In case of interference move speakers away from such equipment. Do not place any credit or any cards containing magnetic stripes on the speakers.
- Do not place sources of electronic interference (i.e., cordless phones) on the speakers, as it may cause interference and distort sound.
- Do not place and operate the speakers near any source of open flame or direct heat.
- Do not place any objects containing flammable liquids, substances, or liquefiable substances on or near the speakers.
- Only connect the speakers to a sound source corresponding to specifications provided in this manual. Doing otherwise might damage your equipment or speakers.



- Avoid staying near the speakers operating at high volume. Prolonged exposure to high levels of sound can damage your hearing.
- This speaker system is designed and manufactured for home use. It must not be used for continuous sound distribution at high volumes, i.e., in discos or concerts. Doing so may cause irreversible damage to the speakers.

3. Installation

3.1. Unpacking

Please follow the guidelines provided below carefully:

- At least 2 adults should handle unpacking and positioning of the speakers.
- Unpack the speakers as close to their final position as possible.
- Use proper tools for unpacking. Avoid inserting sharp objects too deep in the packaging to avoid damaging the contents.
- While unpacking avoid wearing any sharp items on you or your clothing to prevent any scratches to speaker finish.
- Retain original packaging and all its elements for possible future transportation.



- Do not touch the drivers during the installation.

When unpacked, please ensure that all the package components listed in this manual's section 3.2 are present. If any of the components are missing, contact us at **support@silentpound.com** immediately.

3.2. Package contents

Your newly acquired high end speaker system consists of:

- 2 loudspeakers;
- 2 magnetic back cover grilles;
- 2 banana plug to spade adapters;
- 8 mounting feet;
- Owner's manual;
- Owner's certificate.

3.3 Assembly

After unpacking the speakers, gently lay them on the back side. Be sure to put a soft towel or any other soft material to avoid scratching the speaker finish or your flooring.

Screw in the provided mounting feet, as far, as they can go without applying any excess force. Return speakers to upright position.

Move the speakers to their final position as described in section 3.4 below.

Gently snap on the magnetic cover grilles.



3.4. Connecting, positioning and fine-tuning the speakers

1. Ideal room size is from 25 m², acoustically unprepared rooms with concrete or brick walls or other sound-reflecting surfaces.
2. Ideally, the room should be rectangular in shape and the wall against which the loudspeakers are placed should be a short wall.
3. The speakers must be set back from the rear wall by a minimum distance of 60 cm (100 cm is optimal).
4. It is desirable that the distance from the side walls to the speakers is uniform and at least 100 cm is optimal.
5. The angle of rotation (toe-in) of the speakers also has influence. Varying the angle of rotation can give different results in terms of stage width. It is recommended to turn the speakers towards the listener.

6. The listener position is best if you are in a triangle between the speakers, with all sides of the triangle equal.

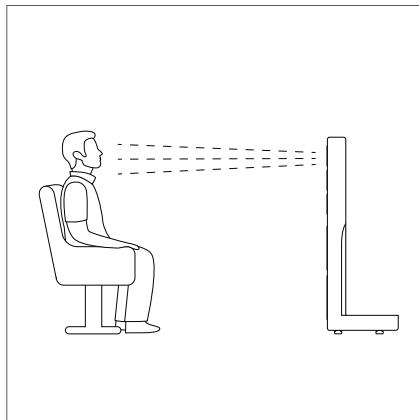
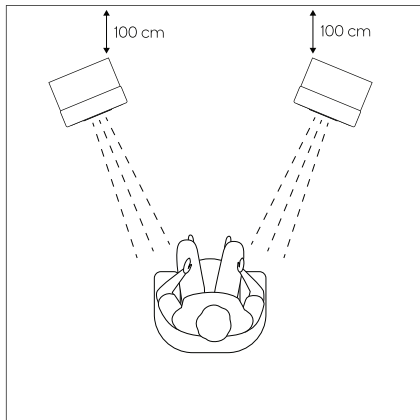



7. It is preferable to have the sound behind the listener not to be reflected. If there is no space for the sound waves to travel further and you have a wall behind your head, it is preferable to hang a sound absorbing solution.

3.5. First operation

Please keep in mind, that for speakers to reach their full potential, a "burning-in" period of 200 hours of playback is required.

3.6 Treble and Bass Switches

The Challenger features a passive crossover with treble and bass switches, allowing adjustment of both bass and treble. Both switches can be accessed from the back of the speakers by removing the magnetic dust cover. They are located on either side of the bottom woofer and offer the following positions:

- Bass: 0 dB or -3 dB
- Treble: 0 dB or +2 dB

Adjusting treble or bass levels can be quite beneficial for several reasons:



- Tailored Sound to Room Acoustics. Every room has its unique acoustic properties, influenced by its size, shape, and contents (such as furniture and wall materials). These factors can dramatically affect the perceived balance of bass and treble. An adjustable crossover allows listeners to compensate for these acoustic characteristics, enhancing the overall sound quality and accuracy in their specific listening environment.

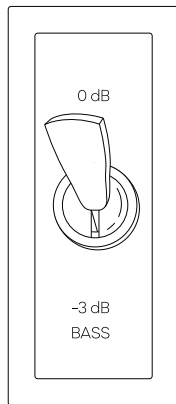
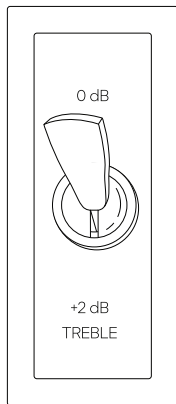

- **Personal Listening Preferences.** Individual preferences for bass and treble levels can vary widely. Some listeners may prefer a brighter sound with more treble, while others might enjoy a warmer sound with enhanced bass. Upgrading the crossover to include adjustment capabilities allows users to customize the sound according to their personal taste.
- **Compatibility with Other Components.** High-end audio systems are often composed of components from different manufacturers, each with its own sonic characteristics. An adjustable crossover can help blend the sound of the different drivers more seamlessly, ensuring that the speakers perform optimally as a cohesive unit.



4. Maintenance and Cleaning

Silent Pound speakers do not require any particular maintenance except for general regular cleaning:

- The cabinet surfaces only require dusting. A damp or dry cloth might be used if required. Do not use any cleaning agents on the cabinets. Do not touch the drivers to avoid any damage.
- The grille fabric may be cleaned with a normal clothes brush whilst the grille is detached from the cabinet.
- Any excess dust on the drivers should be removed using an antistatic soft cleaning duster.
- When speakers are not in use for prolonged periods of time, attach the speaker grilles to prevent excess dust on the drivers.

5. Technical Specifications

- Design: 3.5 - way floor standing constant directivity speakers featuring patent pending midrange enclosure
- Sensitivity: 88 dB (2.83 V / 1m)
- Frequency range: 30 Hz – 18 000 Hz
- Impedance: 4 Ω
- Recommended amplifier: 100 – 400 W
- Dimensions (W/D/H): 36x15(33)x124 cm
- Weight: 60 kg / unit.

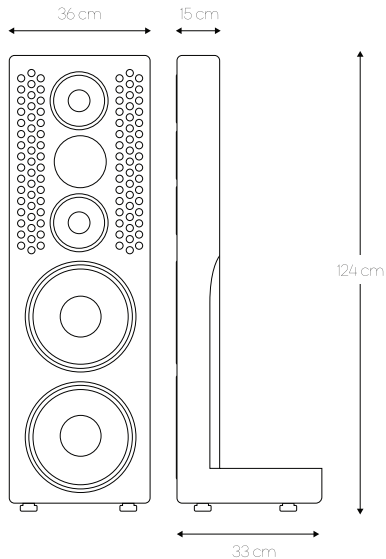



6. Warranty Activation Card

- Customer Name: _____
- Purchase Date: _____
- Product Model: _____
- Serial Number: _____
- Sold by (dealer, country): _____
- Signature: _____
- Date (YY/MM/DD): _____

CONTACT INFORMATION



SP Audio, MB

Vaizganto 9-21, LT44225 Kaunas, Lithuania

General inquiries: hello@silentpound.com

Warranty and support: support@silentpound.com

facebook.com/silentpound

instagram.com/silent_pound

www.silentpound.com